



PARKING OCCUPANCY SURVEY

PART 1: CAR PARK INFORMATION

Car Park/Building Name: _____

Car Park Operational Hours: _____

	Car	Motorcycle
Total Number of Lots		
Number of Lots reserved for Season Parking		
Are lots open to public / non-tenant?	Yes / No *	Yes / No *

* Please delete where inappropriate

Number of Loading/Unloading Bays: _____ Minimum Height Clearance: _____
(if applicable)

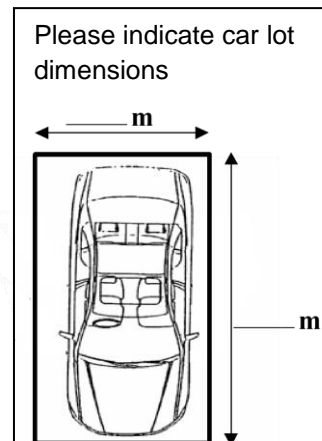

PART 2: PARKING OCCUPANCY

Date of Survey	Day 1 __ / __ / __ (dd/mm/yy)		Day 2 __ / __ / __ (dd/mm/yy)		Day 3 __ / __ / __ (dd/mm/yy)	
	Total Number of Occupied Lots					
Time (Hrs)	Car	Motorcycle	Car	Motorcycle	Car	Motorcycle
0800						
0900						
1000						
1100						
1200						
1300						
1400						
1500						
1600						
1700						
1800						
1900						
2000						
2100						
2200						

Notes:

1. Please indicate the number of occupied car and motorcycle lots at one hour intervals between 08.00am and 10.00pm for the three days
2. If the car park is not in operation for a specific time slot, survey is not required for that period.

PART 3: SEASON PARKING

Please indicate the total number of season parking tickets *sold* in the past 3 months:

Car MM/YYYY: _____ MM/YYYY: _____ MM/YYYY: _____
 Motorcycle MM/YYYY: _____ MM/YYYY: _____ MM/YYYY: _____

Is there a waiting list for season parking tickets for cars? Yes / No * (*Please delete where inappropriate*)
 If yes, please indicate average waiting time _____ weeks / months *

Is there a waiting list for season parking tickets for motorcycles? Yes / No *
 If yes, please indicate average waiting time _____ weeks / months *

Please indicate the total number of *free* parking labels issued in the past 3 months:

Car MM/YYYY: _____ MM/YYYY: _____ MM/YYYY: _____
 Motorcycle MM/YYYY: _____ MM/YYYY: _____ MM/YYYY: _____

PART 4: PARKING CHARGES

Please indicate the operational hours and parking charges imposed in your car park as at **{date of application}**.

		Operational Hours	** Parking Charges		
			Car	Motor-cycle	Lorry
Monday to Friday	Hourly / Half-hourly*				
	Per Entry				
Saturdays	Hourly / Half-hourly*				
	Per Entry				
Sundays	Hourly / Half-hourly*				
	Per Entry				
Season Parking Charges	Tenant				
	Non-Tenant				

* *Please delete when inappropriate*

** *Please indicate rate structure e.g. 1st hour \$2.00 and subsequent hour \$1.00 or \$2.00 per entry.*

Please indicate how parking charges are currently collected. (*Please tick*)

- Full EPS (ERP-type Parking System)
 Magnetic Ticket
 Semi EPS
 Manual operator
 Cashcard System
 Others (*please state*) _____

PART 5: PARTICULARS OF CONTACT PERSON

I confirm that the information given above is complete and correct as of today.

Signature of Authorised Officer

Date: _____

Name : _____

Company : _____

Contact No. : _____

Email : _____

If you have suggestions on how we can improve the next Parking Survey, please indicate them below:

~ End of Survey ~

Thank you for your co-operation. Your completed return will be treated as strictly confidential.