

Re:bench

— CATALOGUE —

NEW DESIGNS FROM 'RE:BENCH'

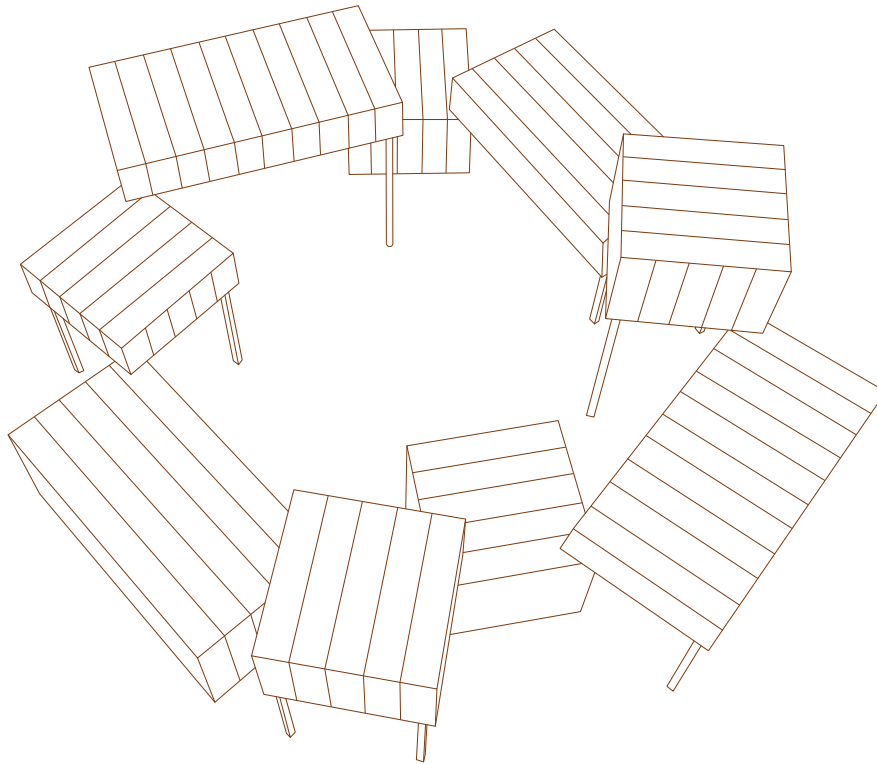

BRIDGING BENCH

Bridging Bench is at parts a stool, at parts a chair, at parts a bar seat, and at parts a table. Children may find the opportunity to play around its staggering levels. Teenagers may use the tables for a casual picnic. The elderly may just stop by for a minute's rest. The bench welcomes all to use it differently, to sit at any level they prefer. The bench acts as an inversion of the old stadium, where spectators can sit and enjoy the activities happening around them in all directions. The memories of the old stadium lives on, in both physical form and experiential space.

By Iven Peh & Kevin Huang

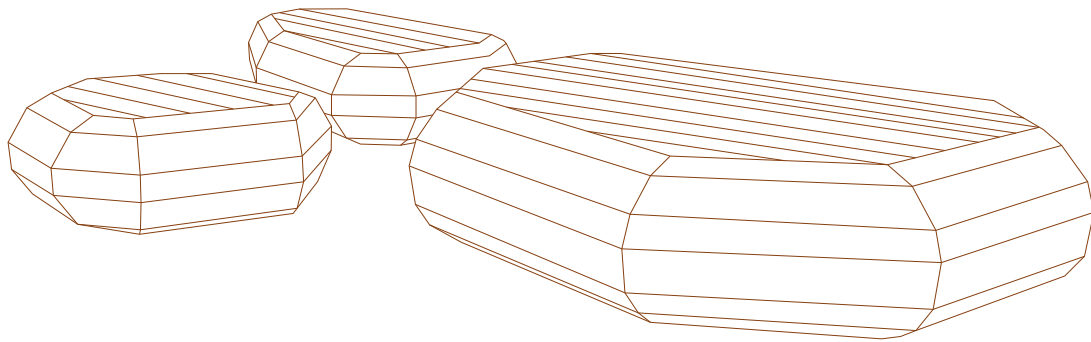

BUBBLE BENCH

My inspiration for the design of Bubble Bench is from the water bubbles that are produced from the motion of swimming and water play. The design comprises three individual benches that allow people to sit face to face and communicate with one another.

By Xie Wenru

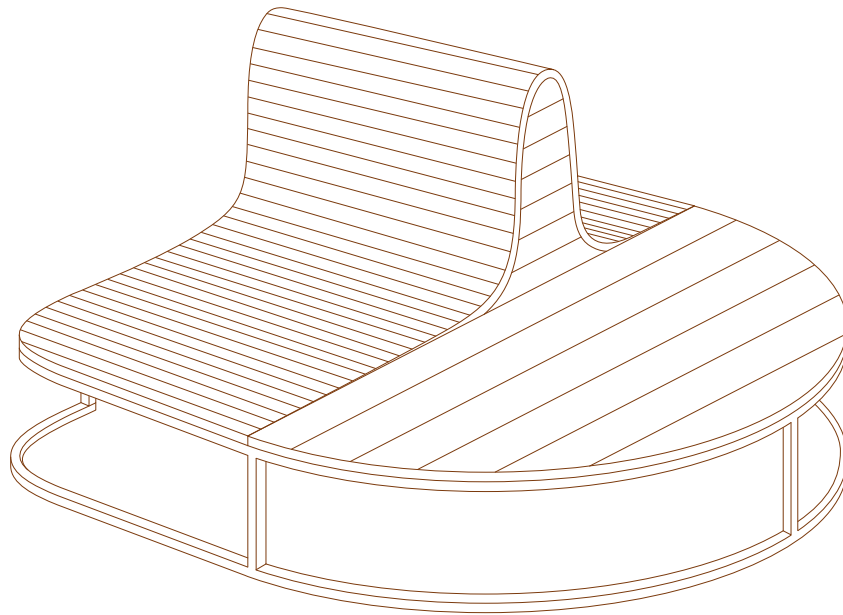

FLOW

The former National Stadium was a place of memories, where Singaporeans gathered to witness moments together. Flow is inspired by picnic gatherings, a simple yet intimate activity, just like how the National Stadium created cherished memories by bringing everyone together.

By Valerie Chua Qi Wei

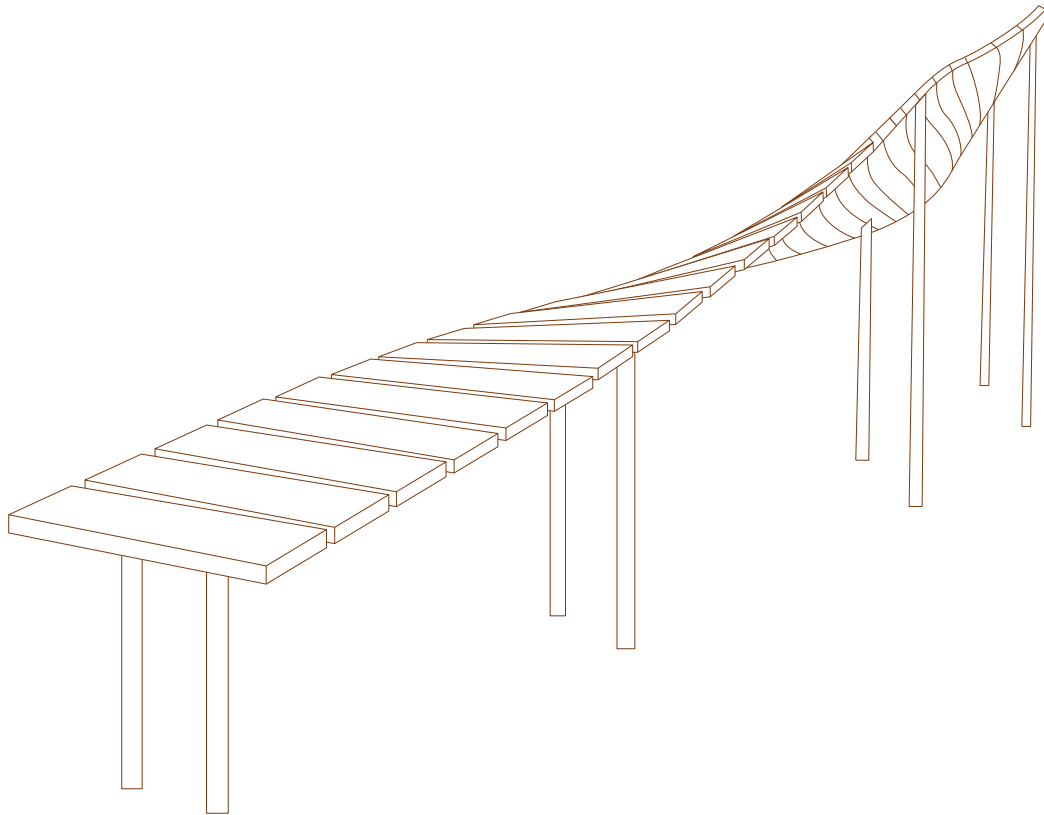

GATHER

Gather was inspired by the movement of the athlete, the movement of calisthenics, gymnastics, parkour and acrobatics. The bench provides different seating heights to suit individual user preferences as well as to facilitate human interaction.

By Jane Yu Wai Ching

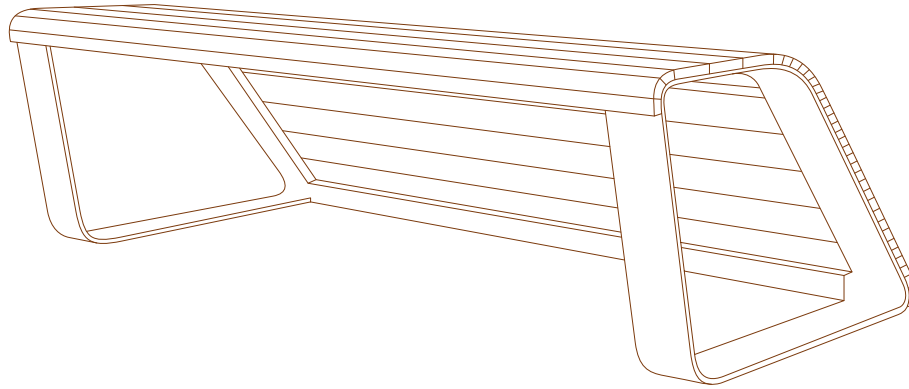

GOAL!

The GOAL! bench is conceptualised to function as a goal post using the opening under the seat to encourage spontaneous outdoor play for both adults and children. Users can also recline on the sloping wooden back while sitting on the ground, or sit on the seating surface. The GOAL! bench celebrates collective memories and honours the milestones of Singapore soccer witnessed by the former National Stadium and engages a new generation of children by encouraging them to embrace the spontaneity of outdoor play and discover a love of the beautiful game.

By Samantha Tan Shu Juan

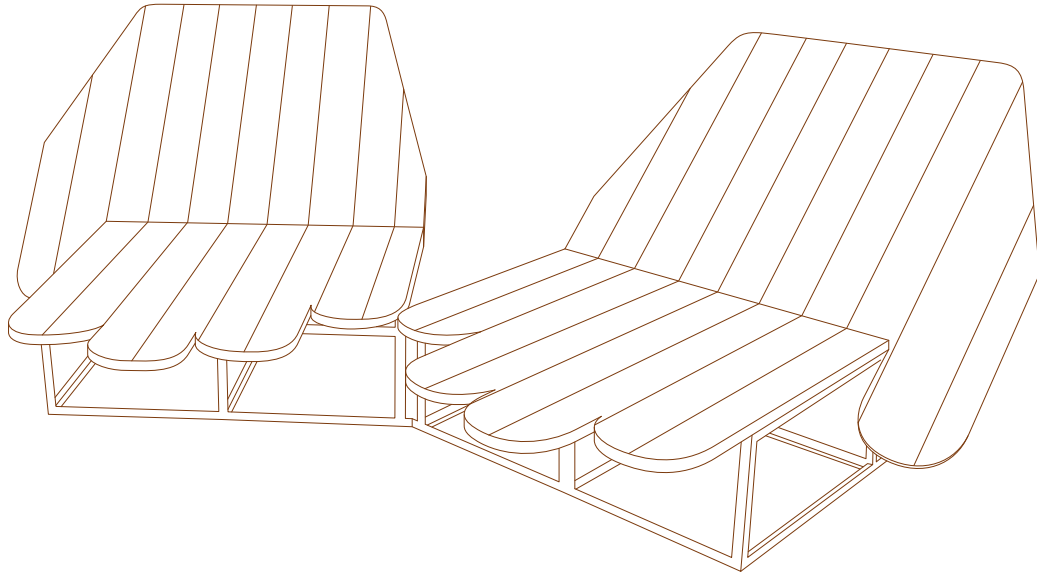

HAND OVER

Through its years of service, between the football matches and displays of fireworks, our former National Stadium saw its fair share of rain and shine. The benches served dutifully in the stadium, and developed deep wrinkles and scars under the mercy of time and weather. Kept in their 'raw' state and shaped into a set of hands, the wooden planks will develop deeper wrinkles as they continue to grow older. The hands themselves are shaped in a gesture that suggests they are 'providing'; an homage to the stadium's years of service. I wish to create a renewed purpose for the benches while allowing the history that is recorded in them to continue developing, until the day they can no longer function.

By Goh Zheng Ning

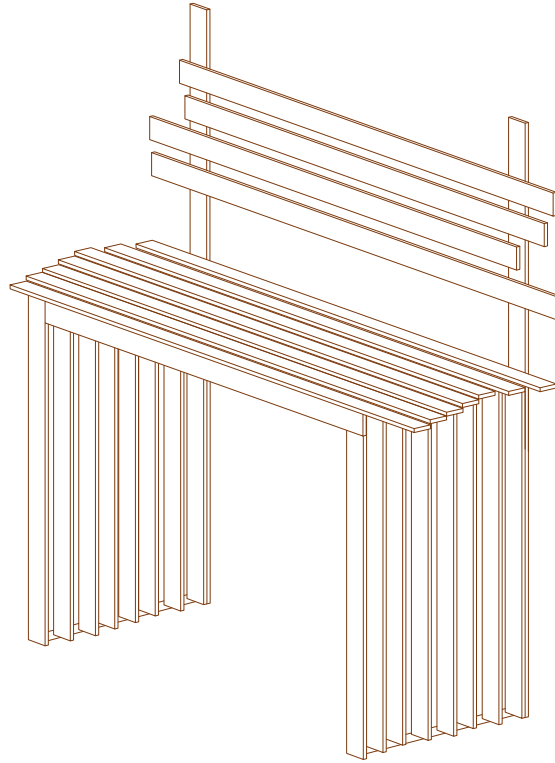

HORIZON

Kallang is fun-filled with activities and attractions that will leave families and individuals alike satisfied. The super-sizing of the bench (about triple the usual height) is a humorous, parallel response to the fun factor and enjoyable experiences at Kallang whether it is going to a football match or rowing in the river. Horizon serves as a platform that elevates everyone to a higher common ground, looking towards the horizon, in a single direction with a common purpose. It is purposeful in reflecting the past and upon the future.

By Muafah Binte Amran

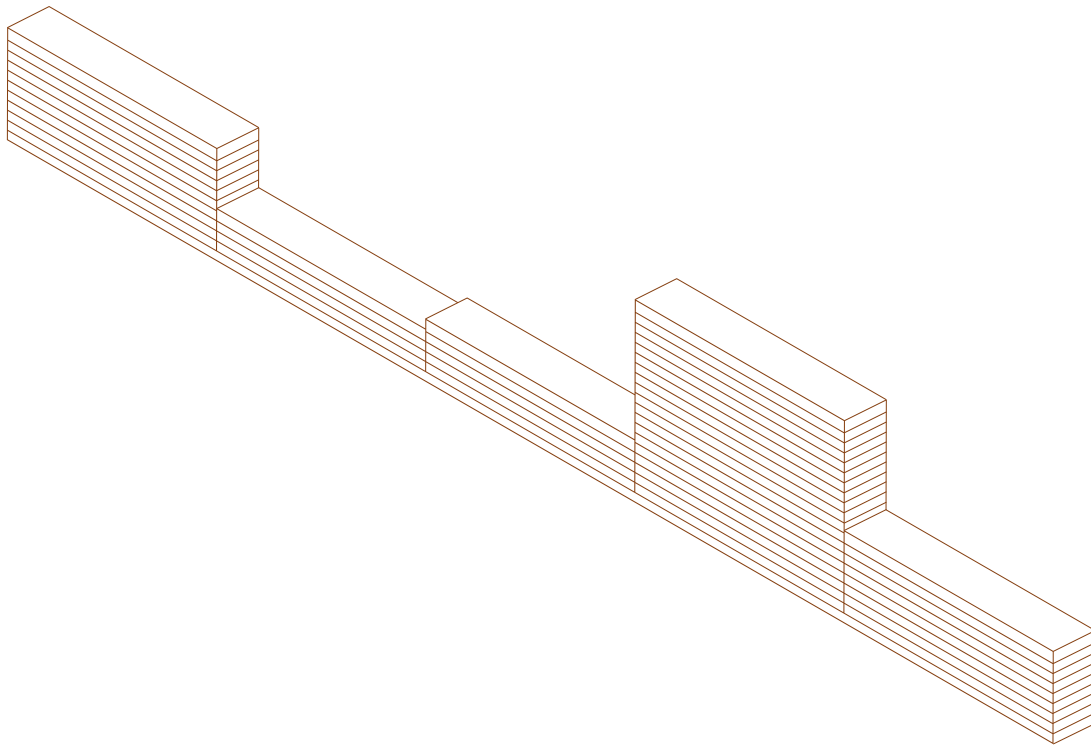

RESONANCE

The salvaged wood from the stadium are now repurposed into a public bench that resonates with us not just as remaining pieces of wood, but one that is in sync with our natural patterns. The heights of the seats are designed by stacking the wood in numbers that approximate the ratios exhibited in naturally occurring patterns. By designing the salvaged planks' sitting heights as such, it uses the public bench as a medium that resonates not just as a memory of the former stadium, but also as a connection to the history between us and the salvaged wood.

By Yeo Ker Siang

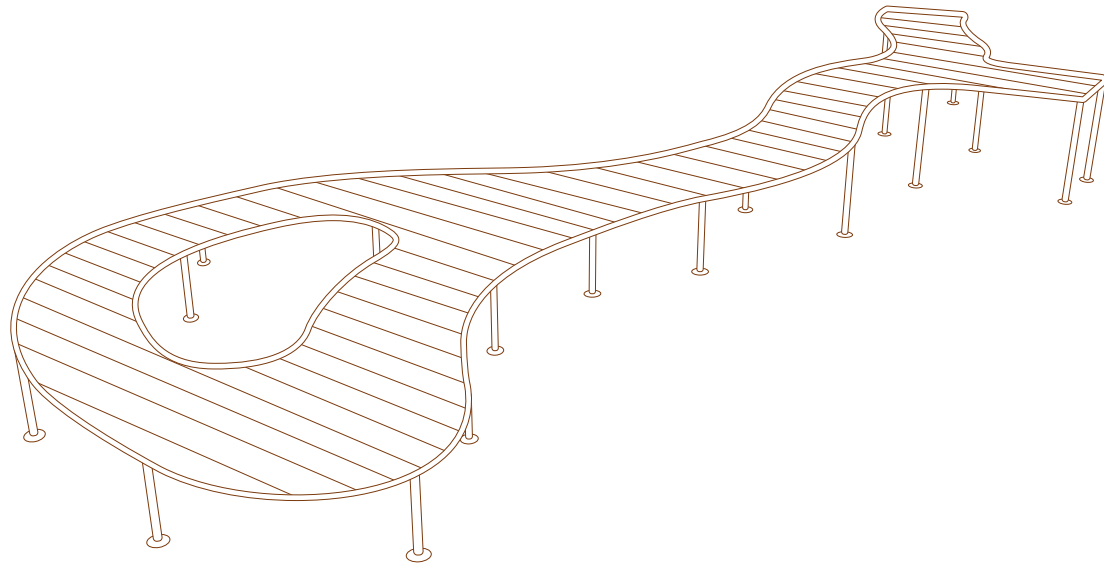

RIVERO

Rivero is a bench inspired by the Kallang River. The river represents communication – people lived or traded goods along the river in early times. Symbolically, branches of water blend into one river and flows into the sea, signifying unity.

By Guan Haotian

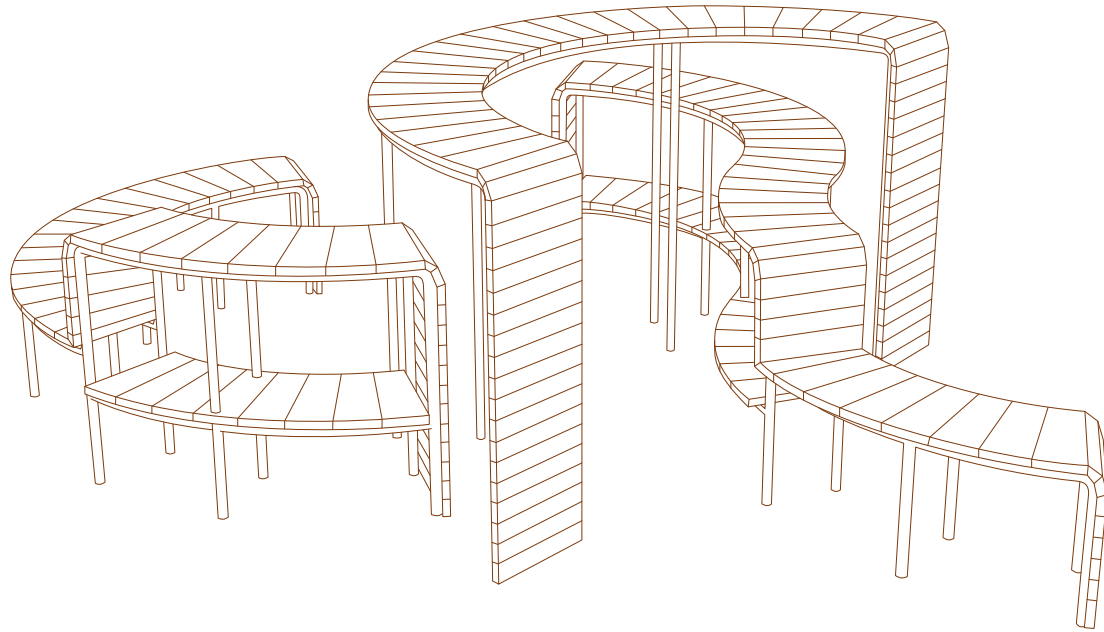

SCULPACE BENCH

The Sculpace Bench aims to express and provide a rest area for different outdoor activities. The unconstrained shape of the bench design is based on circular elements because the round shape gathers people and creates cozy and comfortable spaces that let people sit face to face. By designing for various sitting and standing positions, sculptural visual outcomes are created, and people can choose their preferred sitting position.

By Yu Yang

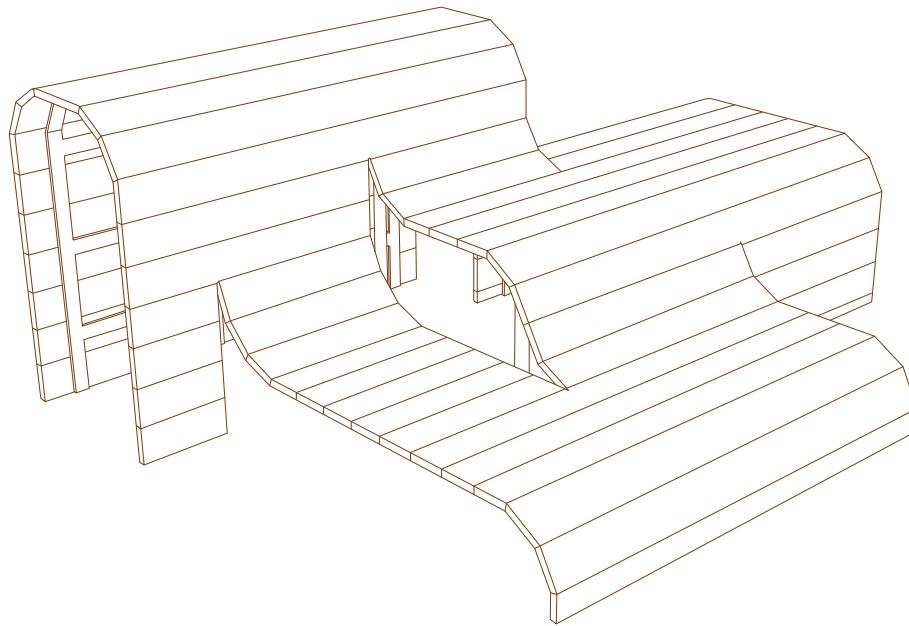

SILHOUETTE

The benches of the National Stadium were the embodiment of excitement. They lent a breather in between moments of cheering and acted as the platforms on which we ran and jumped on and off when finding seats. I want to capture the emotions and feelings associated with the stadium benches in a public bench, reminding people of the moments that they spent there. Silhouette references the profile of the bleachers, paying homage to the stadium seats. The large sitting area allows people to freely sit as they please, while the different levels invite the young ones to jump and climb around like they did in the stadium, blurring the line between a bench and an interactive space.

By Chin Guo Hong

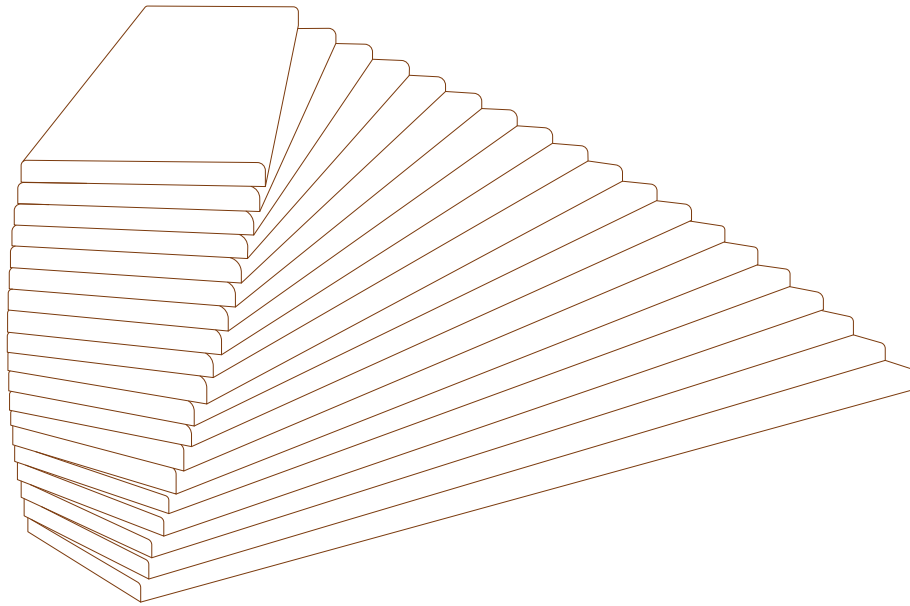

STACK

The design is inspired by a stacked harmonised seat where people used to gather. The planks are rotated equally about an axis, reminiscent of stairs that remind us of the continuous improvement from the past towards a brighter future.

By Koh Min Xiang

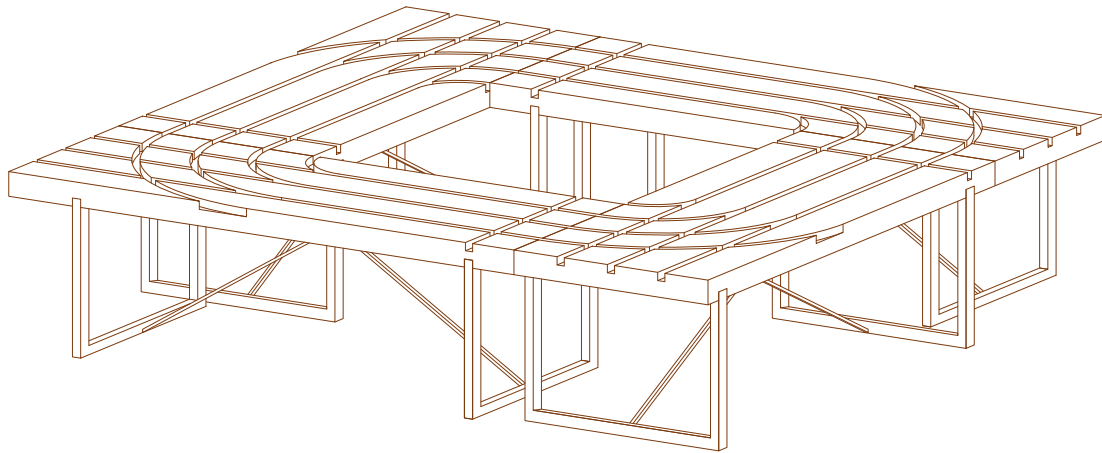

TRACK

Track is a bench that borders between simplicity and the memory of a former, beloved landmark. Lines are etched onto the surface to give the visage of a running track, with the starting line on one end and a turn on the other, symbolic of the one in the stadium. The simplicity of the design gives the bench a fresh look, and the lines can be connected from one bench to another if there is more than one, forming a completed running track.

By Reynard Seah Jun Hao

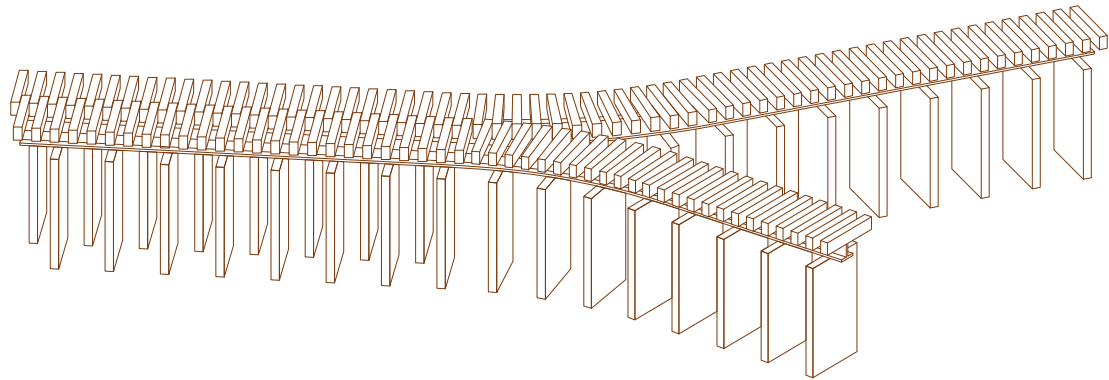

ZIP

The former National Stadium was more than just a building, it was an iconic landmark and source of national pride. People will always be taken back to those sad, happy and proud moments when they are united regardless of different backgrounds while cheering on the best of Singapore. This bench is designed as celebration, reminder, and symbol to commemorate the unity of Singaporeans. The memories of sharing the same goals and moving toward the same dream are interpreted by two linear benches merged into one, interconnected – supporting each other – united.

By Edison Gunawan

EXISTING DESIGNS FROM 'BENCH'

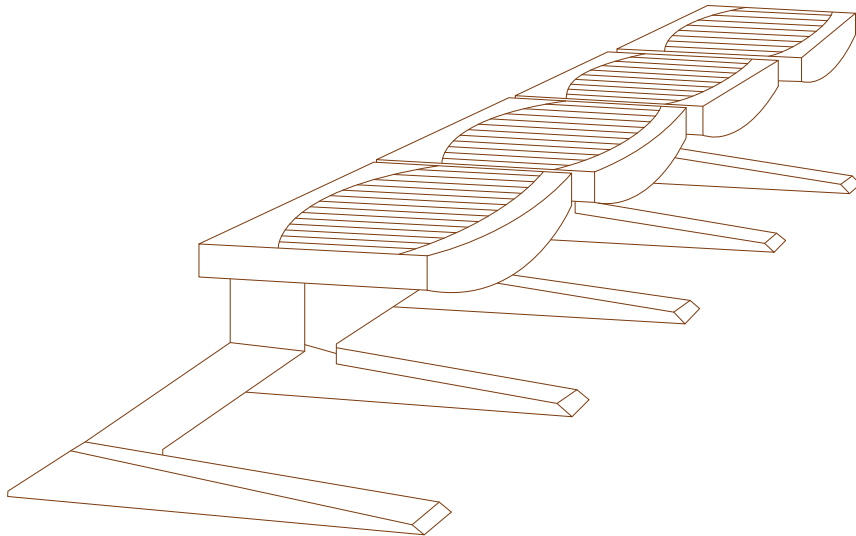

1973

The former stadium is one of the more iconic buildings in post-independent Singapore. In its heyday in the 1970s, the stadium evolved from a utilitarian structure to a symbol that captured the imagination of a nation. Over the years, the stadium meant different things to different people - the concerts, the parades.

Its architecture will always be remembered for its iconic floodlights, distinctive rooflines, the red track and its weathered wooden galleries.

By Peter Chen

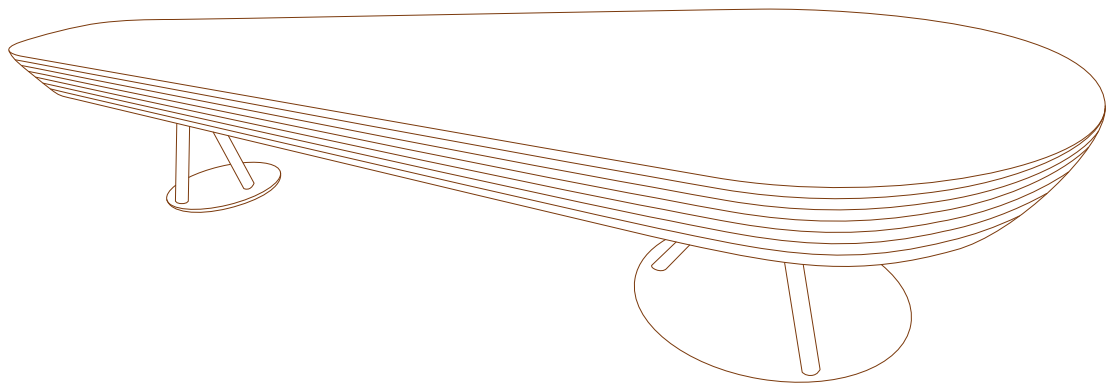

BENCH AS SCULPTURE

My memory of the former stadium includes the great moments I had during the Malaysian Cup Football. This was the real roar! Ironically, the stadium icon did not stir up my spirits in those days. Free form in the shape of a fallen leaf on the stadium grounds outside the stadium automatically comes to mind. Recycling the planks to form a LEAF shape resembles the stadium form.

By Tang Guan Bee

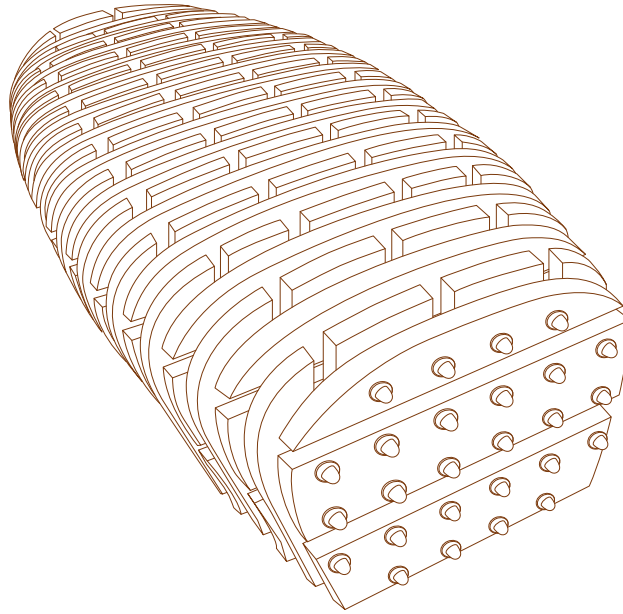

BENCH / STADIUM

The stratification of the ziggurat-like skin reflects the texture of the former stadium's seating. The curved, external surface is new. But the natural, textured, weathered grain of the original planks will be revealed within the interior of the bench. The form, the inverted planks and the longevity of the material suggests solidity, a rock-like permanence to pay homage to the absent stadium. The elliptical shape, symmetrical for efficiency, is a cultural memory, an echo, rising from the dust of the preceding civic icon.

By Andrew Crombie, MKPL Architects

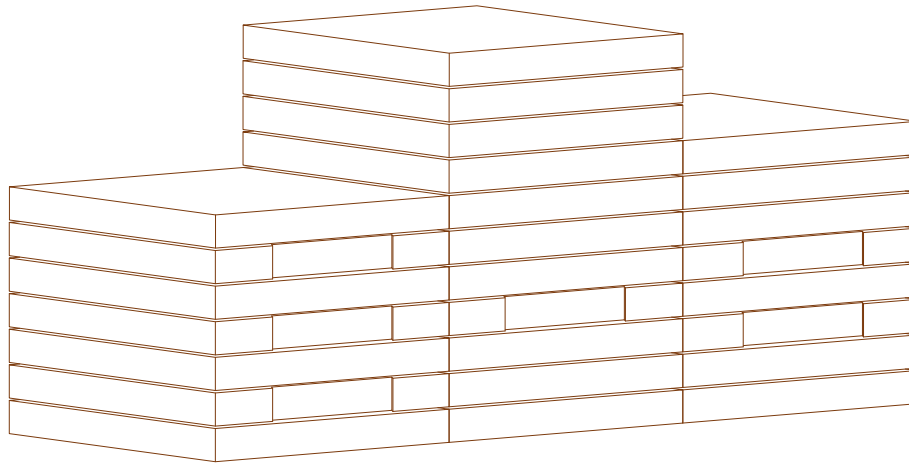

BENCHMARK SAT

The design uses the victory podiums as inspiration to pay tribute to the former Stadium. At the front and rear elevations, the deliberate omission of horizontal planks reveal the Chinese characters “一”, “二” and “三”, representing the podium’s first, second and third places respectively. Likewise, when viewed from the top, the design displays the Roman numerals, “I”, “II” and “III”. The bench, with three levels, opens up a variety of uses for adults and children alike – to rest, play and exercise on. While it is inherently human to strive for the first place, Benchmark Sat allows the user to choose a preferred seat, thereby setting his or her own comfortable benchmark.

By &Larry

The word "DREAM" is rendered in a 3D, wireframe style. Each letter is a thick, hollow block with a perspective view, giving it a three-dimensional appearance. The letters are arranged in a slightly staggered, receding line from left to right.

DREAM

The design is inspired by the legendary “dream team” of the 1990s. Top local and key import players like Fandi, Malek, Jang Jung and Alistair Edwards, who were then playing for Malaysian teams all returning to help the Lions regain their status in Semi-Pro League and eventually won the Malaysia Cup. They inspired and united the nation. There are vivid memories of the glorious days sitting in a packed stadium filled with fellow passionate supporters.

By PHUNK

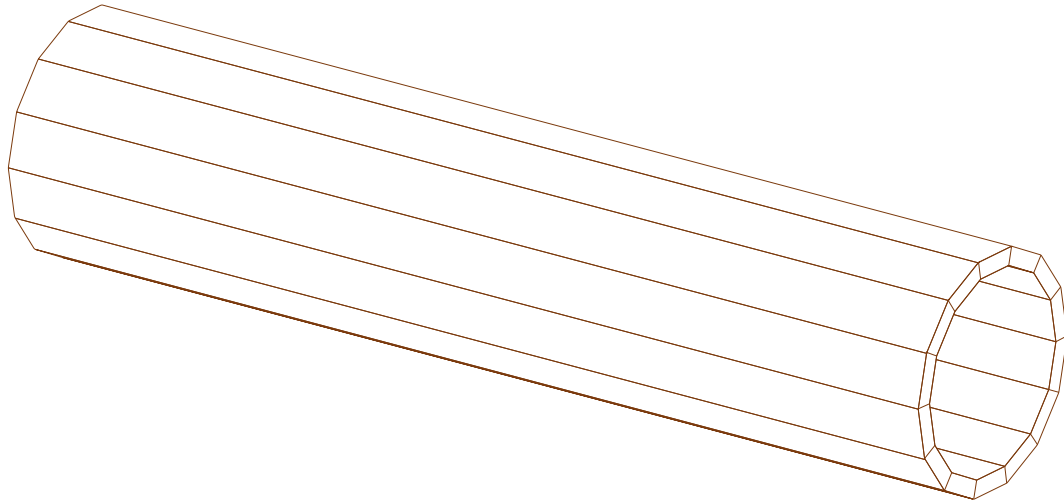

LUMBER

Once logged from trees, the seating planks of the former stadium are returned to the primordial state of a trunk as a tribute to the stadium - a genesis of Singapore's progress through its support of many national events. With the worn out surface of the planks from years of weathering, they lie together like a fallen trunk where one would instinctively sit, offering the same support to passers-by as it once rendered to crowds.

By Hans Tan

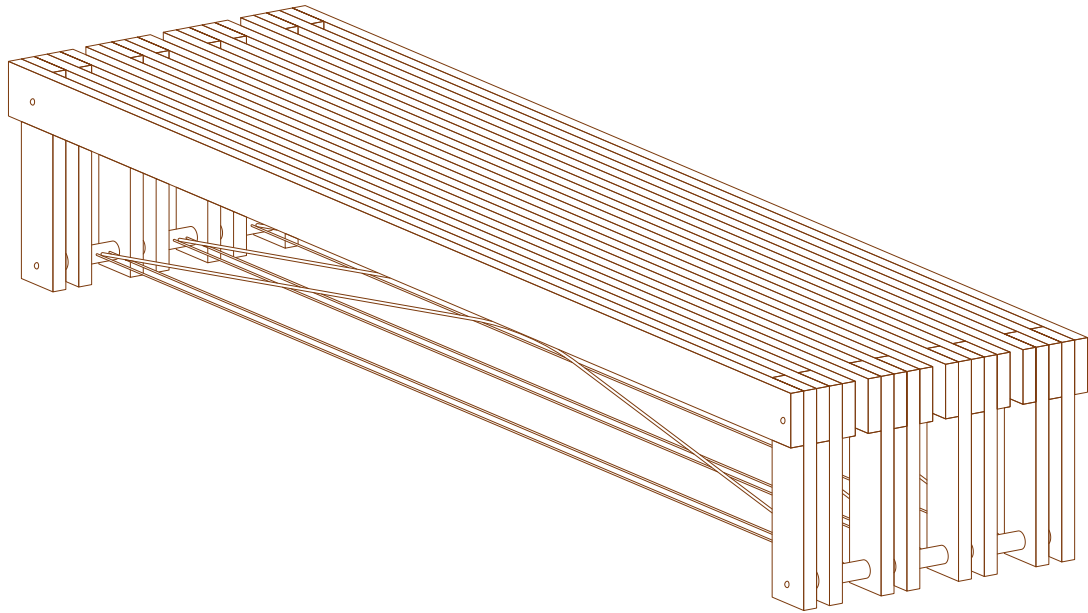

STADIUM BENCH

The design seeks to keep the sense of time and history visible and tangible. The bench is expressed as a collection of objects where each plank is seen as an individual relic from the former stadium. The natural state of the planks is retained, to reflect the weathering of the planks, from the freshly sawn planks when Singapore became a modern nation, to silvered, aged wood many years later. The ends of the planks are trimmed, distinguishing old and new.

By Wong Mun Summ & Richard Hassell, WOHA

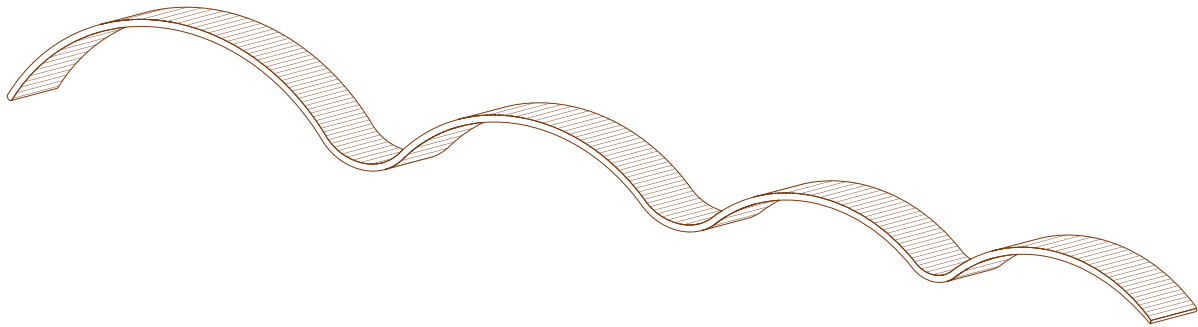

THE KALLANG WAVE

The design attempts to capture the spirit of the Kallang Wave, a memorable way of cheering across the former stadium. Hence, the creation of a 9-m long bench that rises and drops in a wave like pattern, enabling people to use the bench in many different ways. The exaggerated length is a reminder of the participation in something larger than oneself. It reflects the ups and downs of a sports game and the Kallang Wave. The bench offers an opportunity for reflection and remembrance of the former stadium.

By Ministry of Design